

Please note that the links in the PEARL logotype above are “live” and can be used to direct your web browser to our site or to open an e-mail message window addressed to ourselves.

To view our item listings on eBay, [click here](#).

To see the feedback we have left for our customers, [click here](#).

This document has been prepared as a public service . Any and all trademarks and logotypes used herein are the property of their owners.

It is our intent to provide this document in accordance with the stipulations with respect to “fair use” as delineated in Copyrights - Chapter 1: Subject Matter and Scope of Copyright; Sec. 107. Limitations on exclusive rights: Fair Use.

Public access to copy of this document is provided on the website of Cornell Law School (<http://www4.law.cornell.edu/uscode/17/107.html>) and is here reproduced below::

Sec. 107. - Limitations on exclusive rights: Fair Use

Notwithstanding the provisions of sections 106 and 106A, the fair use of a copyrighted work, including such use by reproduction in copies or phonorecords or by any other means specified by that section, for purposes such as criticism, comment, news reporting, teaching (including multiple copies for classroom use), scholarship, or research, is not an infringement of copyright. In determining whether the use made of a work in any particular case is a fair use the factors to be considered shall include:

- 1 - the purpose and character of the use, including whether such use is of a commercial nature or is for nonprofit educational purposes;
- 2 - the nature of the copyrighted work;
- 3 - the amount and substantiality of the portion used in relation to the copyrighted work as a whole; and
- 4 - the effect of the use upon the potential market for or value of the copyrighted work.

The fact that a work is unpublished shall not itself bar a finding of fair use if such finding is made upon consideration of all the above factors

Conventional Parallel Connection

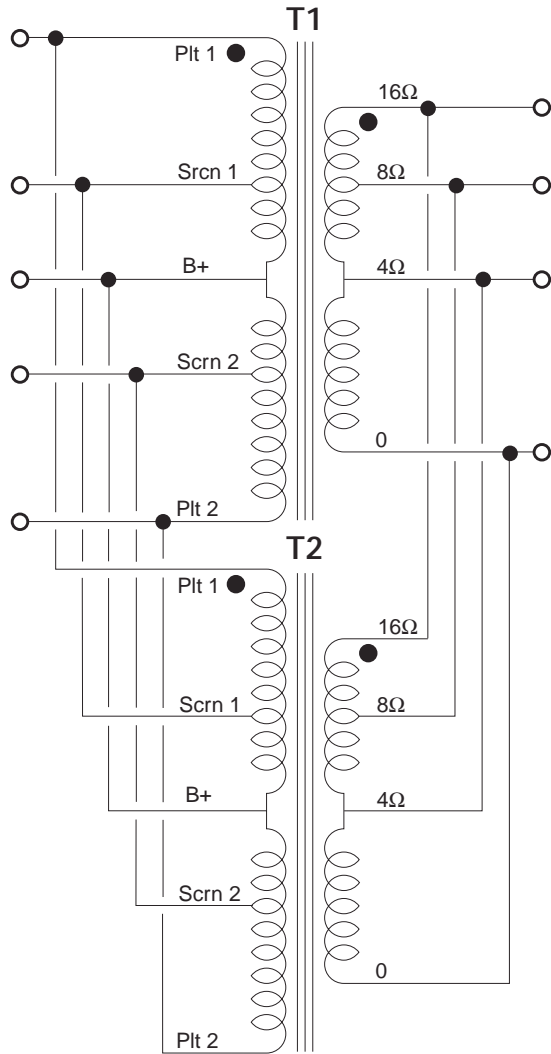

Opposing Parallel Connection

